

NEW DESIGN SAW SET No. 42SS / NOUVEL OUTIL A AVOYER LES SCIES No 42SS

SAW SET No. 43 OUTIL A AVOYER LES SCIES NO 43

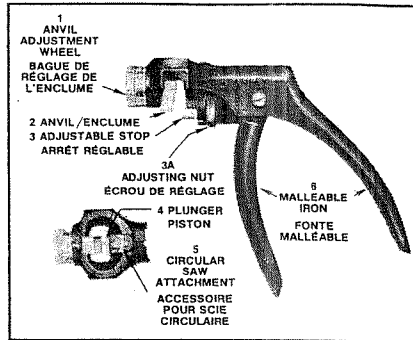

FEATURES:

1. Micro-setting calibrated anvil adjustment wheel with positive locking screw — for securing desired setting.
2. Hardened and tempered tool steel anvil.
3. Adjustable graduated positive saw stop — provides compensation for variation in saw blade thickness to permit increasing the amount of set per tooth when desirable.
4. Easy, positive single action plunger — provides maximum setting power with minimum effort. Plunger of hardened and tempered tool steel.
5. Circular saw setting attachment provided in convenient location for quick application.

6. Pistol grip design originated by Stanley — for greater comfort and leverage. Body and lever made of malleable iron, practically unbreakable.

Capacity: Back, panel, hand and small circular saws, 18 gauge and thinner having from 4 to 16 points to the inch.

ADJUSTMENTS:

The first adjustment to be considered when using this new saw set is the stop (No. 3) against which the saw blade is supported when the plunger (No. 4) is setting a tooth. The side of this stop has 3 graduation lines and when it leaves the factory, it is set on the middle line which is for the average saw thickness. Normally you want to adjust this stop so that the blade of the saw is at right angles to the plunger when resting against the stop on one side and the point of the anvil (No. 2) on the other. For thicker or thinner saw blades, the stop is adjusted to maintain the blade at right angles to the line of travel of the plunger. The stop may also be adjusted to tilt the blade either forwards or backwards in order to obtain more or less angle of set on the tooth.

TO ADJUST THE STOP . . . rotate the adjusting nut (3A) to bring the stop in the desired position. A friction spring is provided to keep the adjusting nut from changing position.

The number on the anvil adjusting wheel (No. 1) indicates an average setting for saws

with a corresponding number of points per inch. There is one less tooth per inch than there is points. (See illustration Figure 8). It should be recognized that it may be necessary to go to a lower number or mark as well as the adjustment of the stop if more set is necessary for green unseasoned wood or a higher number or mark if less set is desired for dry wood. Reference marks on the wheel have also been provided to help the professional saw sharpener who may want to determine his own settings. Once a setting is made, the slotted screw should be tightened to lock this setting against accidental movement.

TO ADJUST THE ANVIL SETTING . . . first loosen the slotted screw inside the adjusting wheel (No. 1) and rotate the wheel to bring the numeral that corresponds to the number of points as explained above, opposite the graduation line on the body, being sure to again tighten the locking screw when the desired setting has been made.

This single action saw set provides maximum power for tooth setting with minimum effort making it possible to obtain uniform even settings of the teeth of a saw.

This saw set is carefully designed for long and reliable service but the working parts are replaceable when necessary. When reordering parts for No. 42SS Saw Set be sure to specify the *complete* number shown inside the handle.

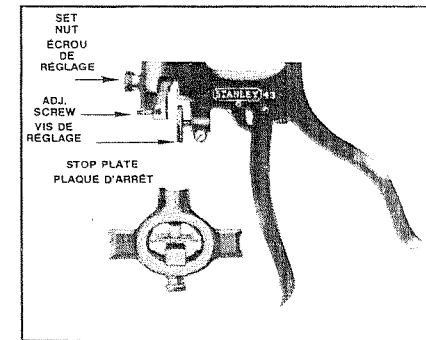

Capacity: Large Cross Cut Saws such as Buck Saws, Two Man Saws, and Circular Saws 11 gauge or thinner, having 5 or less teeth to the inch.

This Saw Set is provided with a Stop Plate for adjustment for the thickness of the saw blade. Adjust Stop Plate so that the blade of the saw is at right angles to the plunger when resting against the Stop on one side of the saw blade and the tooth of the saw against the point of the anvil on the other. It can be adjusted for thicker or thinner saw blades as necessary or for slightly more or less set of the saw teeth.

The tool is set for cross cut saws of average thickness. An attachment is furnished for setting *small* circular saws.

STANLEY

PISTOL GRIP SAW SETS

OUTIL A AVOYER LES SCIES

STANLEY helps you do things right

STANLEY vous aide à bien faire les choses

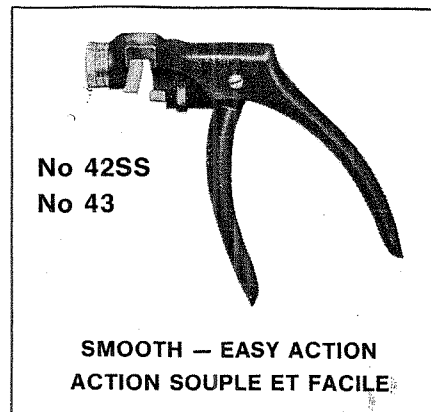

ATTACHMENT FOR CIRCULAR SAWS/ACCESSOIRES POUR SCIES CIRCULAIRES

No 43

The Saw Set No. 43 has the circular saw setting attachment for small circular saws packed loose in the box.

The attachment or stop is placed with the slotted end behind the washer and under the Set Nut shown in the illustration of the No. 43 Saw Set. It is adjusted so that the small end or finger of the stop is in contact with the top of the plunger. Follow general directions as for the setting of the teeth on cross cut or back saws.

L'outil à Avoyer les Scies No 43 renferme dans sa boîte un accessoire pour avoyer les petites scies circulaires.

L'accessoire ou l'arrêt est placé de sorte que l'extrémité encochée soit derrière la rondelle et sous l'écrou de réglage montré à la gravure de l'outil à Avoyer No 43. Il est réglé de sorte que la petite extrémité ou la patte d'arrêt soit en contact avec le dessus du piston. Suivre les instructions générales pour la mise en voie des dents sur des scies à onglets ou de travers.

No 42SS

The Saw Set No. 42SS has the attachment assembled to the frame (No. 5). It is turned around out of the way so it will not interfere with the setting of hand saws. For setting the teeth on circular saws of 18 gauge and thinner, loosen the screw holding this attachment and turn it over. Replace it so that the small end or finger of the attachment is in contact with the top of the plunger. Follow general directions as given for hand saws.

L'outil à Avoyer les Scies No 42SS possède l'accessoire monté au cadre (no 5). Il est tourné de sorte qu'il ne nuiera pas à la mise en voie des scies à main. Pour la mise en voie des dents des scies circulaires de calibre 18 et plus mince, desserrer la vis retenant cet accessoire et le retourner. La replacer de façon que la petite extrémité ou la patte de l'accessoire soit en contact avec le dessus du piston. Suivre les instructions générales telles que données pour les scies à main.

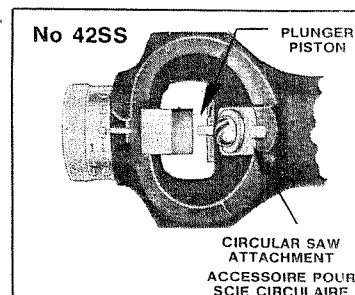
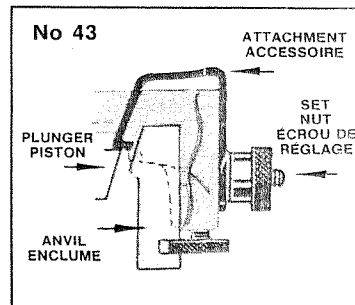

THE STANLEY WORKS OF CANADA LIMITED
Hamilton, Ont. L8L 7X9 Roxton Pond, Que. J0E 1Z0